

Semi-trailer tipper

Steel chassis Domex/Strenx 700, Steel half-pipe box
Hardox 450 NW 55 D. Dedicated for scrap metal transport

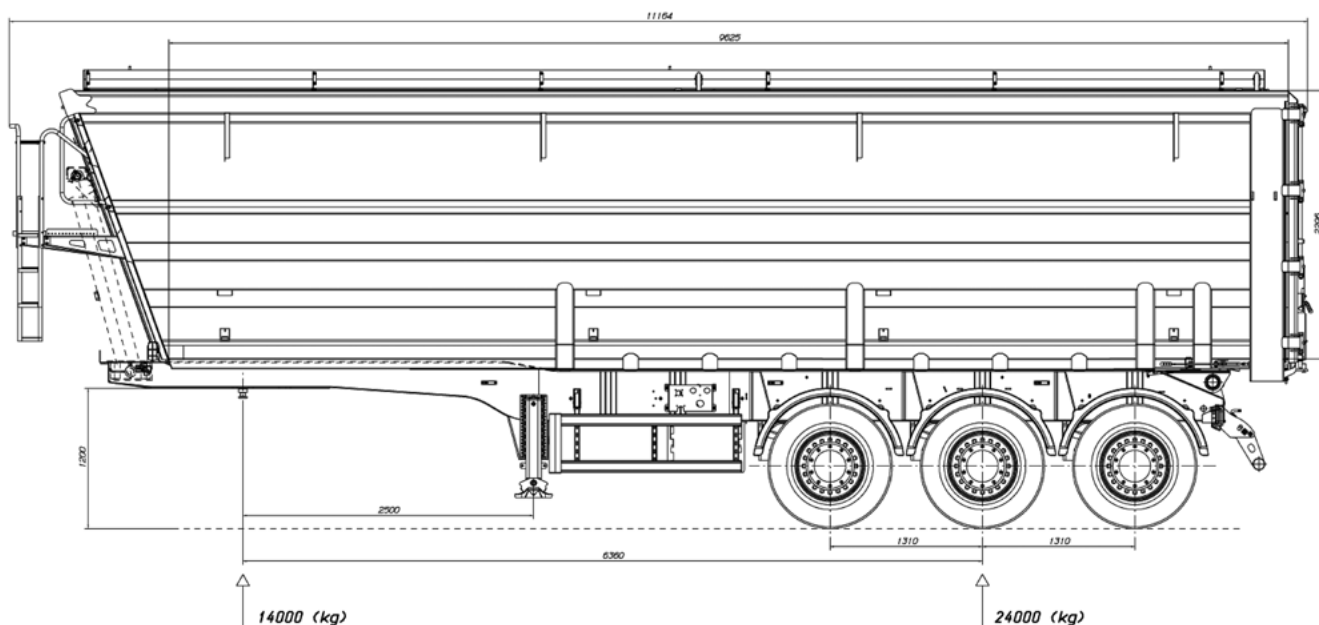

Technical specifications – standard scrap trailer (further options available)

Total volume	55m ²	Maximum gross weight	38,000kg
Inner length of the body	9,625mm	Maximum kingpin load	14,000kg
Inside loading height	2,300 mm	Maximum load on the axles	24,000kg
Width inside the body	2,420mm	Total height	3,760mm
Net weight	approx. 8,400kg	★ Height to the kingpin	1,200mm or 1,150mm
Maximum permissible load	approx. 30,600kg		



BAXLE

LONDON

Chassis

Steel: Domex/Strenx 700. JUMBO type. Total height lowered by 70mm

Domex/Strenx 700 side panel with 2' Jost kingpin

Jost steel support legs: Three DCA Mercedes axles 9T with disc brakes Ø 430mm

Weighing system: VPG

Pneumatic suspension

No lifted axles

★ 24V electric installation Hella/Aspöck in compliance with ECE and ADR

Illuminated registration plate, marker lights

Side LED lights

Reflective boards and triangles

Connecting sockets and EBS sockets on the front wall, without connecting wires

Full EBS brake system KNORR 2S/2M with RSS, compatible with ECE

Automatic parking brake

H-S valve

Raise and lower valve

Manometer measuring air pressure in air springs

Wheels: 10-slot aluminium Speedline, stainless steel nut covers

★ Premium class tyres – 385/65 R 22,5. x7

Continental HTR2, Dunlop SP244 or Bridgestone R168Plus

Half-pipe loading body

Steel: Hardox 450mm

Side walls: Hardox 450 (4 mm bottom, 3mm upper)

Floor: 5mm Hardox 450

Platform mounted in the front of the body with one ladder

Rear closing: Door, closed by two hooks, safe opening from the side of the box. No grain hatch

HYVA FE7030 hydraulic cylinder without the check valve mounted in front of the body

Slanting front wall

Sheet system, UK gearbox

Cross beams. x2

Painted in varnishing chambers

Steel elements grit-blasted before painting

★ Choice of RAL colour: Chassis, body and canvas

Accessories

Two chocks

Toolbox

Water tank

Brush and spade

Mud flaps

Full plastic fenders

Baxle Ltd are the sole UK distributor for Feber Inter-Cars. We supply their full range including parts and accessories.

Please contact us for more information:
info@baxle.co.uk | 020 7511 6885

**These specifications are for our standard scrap trailer
Please get in touch if you require a trailer built to your own specific requirements.**

